



Pallet stacker
pedestrian controlled

Focus ac



Chassis

Of folded frame construction to minimize welding-induced stresses, it offers maximum stability and superior mechanical strength under all traction and storage conditions. The configuration with four fixed points of support offers unique lateral stability. With its easy-adjustment system, the pivoting wheel helps maintain excellent grip, offsetting wear on the drive wheel. The high-visibility bolted masts and laterally positioned steering handle ensure wide visibility during storage, picking and transport operations. The battery compartment is accessed by simply lifting the hinged lid, thus facilitating daily and periodical battery checks and recharging. Particular attention has been given to provide easy access to wearing parts in order to minimize routine maintenance costs.

Masts

OMG masts are made of cold-drawn sections to ensure torsion and bending rigidity. The lift cylinders are outside the profile of the mast, for triplex FFL mast only, and the chains are in a protected position to provide a perfect visual field and operating safety. It is available in simplex, duplex and triplex full free lift mast.

Hydraulic functions

The 3 kW powerful and noiseless motor is highly inductive and the torque delivered offers performance with low current absorption.

Very efficient pump with low noise level. The optional mini-joystick on tiller arm allows the operation without taking the hands off the steering handle.

Drive

Reliable and powerful traction motor capable of meeting the most demanding performance requirements, delivering the necessary power under all load conditions as the translation speed exactly depends on the position of the drive throttle.

Electronic system

The machines are equipped with ac controller and energy recover achieved by:

- releasing the drive throttle;
- reversing the direction of travel.

The electronic control monitor all the machine's functions and allow many adjustments to optimise the performance of the machine, adapting it to the type of work it has to carry out, ensuring low energy consumption and noiseless operation.

Characteristics	1.1	Manufacturer			OMG S.r.l.
	1.2	Model			Focus ac
		Execution			
	1.3	Drive			Electric
	1.4	Operator type			Pedestrian
	1.5	Load capacity / rated load	Q	t	1.2
		Load capacity mast lift	Q	t	/
		Load capacity initial lift	Q	t	/
		Load capacity initial lift + mast contemporaneously	Q	t	/
	1.6	Load centre distance	c	mm	600
1.8	Load distance (centre of load axle to fork face)	x	mm	690	
1.9	Wheelbase	y	mm	1.310	
Weights	2.1	Service weight incl. battery (see line 6.5)		kg	1.122
	2.2	Axle loading, laden front/rear		kg	830 / 1.490
	2.3	Axle loading, unladen front/rear		kg	780 / 342
Wheels Chassis	3.1	Tires			polyurethane
	3.2	Tire size, front		mm	85
	3.3	Tire size, rear		mm	230
	3.4	Additional wheels dimensions		mm	150
	3.5	Wheels, number front / rear (x = driven wheels)		n°	1x + 1 / 2 - 4*
	3.6	Track width, front	b10	mm	570
	3.7	Track width, rear	b11	mm	380
Basic dimensions	4.2	Mast lowered height	h1	mm	2.005
	4.3	Free lift	h2	mm	/
	4.4	Lift height	h3	mm	2.815
	4.5	Mast extended height	h4	mm	3.400
	4.6	Initial lift	h5	mm	/
	4.9	Height of tiller arm in drive position min. / max.	h14	mm	840 / 1.240
	4.15	Forks lowered height	h13	mm	85
	4.19	Overall length	l1	mm	2.020
	4.20	Length to face of forks	l2	m	870
	4.21	Overall width	b1/ b2	mm	850
	4.22	Forks dimensions	s/e/l	mm	70 / 180 / 1.150
	4.25	Width over forks	b5	mm	560
	4.32	Ground clearance, centre of wheelbase	m2	mm	20
	4.33	Aisle width for pallets 1000 x 1200 crossways	Ast	mm	
	4.34	Aisle width for pallets 800 x 1200 lengthways	Ast	mm	2.410
4.35	Turning radius	Wa	mm	1.550	
Performances	5.1	Travel speed laden / unladen		km/h	5.8 / 6
	5.2	Lifting speed laden / unladen		m/s	0.15 / 0.26
	5.3	Lowering speed laden / unladen		m/s	0.40 / 0.30
	5.8	Max gradient performance		%	6 / 10
	5.10	Service brake			Electromagnetic
	Electric motors	6.1	Traction motor, rating S2 60 min		kW
6.2		Lift motor, rating S3 15%		kW	3
6.3		Battery according to DIN 43531 / 35 / 36 A, B, C, no			DIN 43531
6.4		Battery voltage, nominal capacity K5		V/Ah	24 / 270 -345*-375*
6.5		Battery weight		kg	230
6.6		Energy consumption according to VDI cycle		kW/h	
Others	8.1	Type of drive control			ac
	8.4	Sound level at driver's ear according to EN 12 053		dB(A)	< 70
					* option

Technical specification according to VDI 2198, technical values are referred to the standard product. Different masts, different tires, additional equipment, etc. could produce other values. Information and data are given for information only, OMG S.r.l. will have the sole right for technical changes and improvements without giving any notice.

Accessories and special executions

full free lift for triplex mast	orange	pin access keypad	grey
full free lift for duplex mast	grey	anti roll-back system	orange
cold store execution	grey	electronic speed control	orange
capacity 1.400 Kg. for triplex FFL mast	grey	electronic brake system	orange
polyurethane traction wheel	orange	electromagnetic parking brake	orange
push button for vertical operation	grey	BDI hourmeter with lifting cut-off at 80% discharge	orange
double load wheel	grey	built-in charger 24V 35A	grey
lifting / lowering by mini-joystick or push buttons on tiller arm	grey	automatic battery refilling	grey

standard



option



Standard masts

Denomination		Mast lowered height	Lift height	Total lift height	Mast extended height	Free lift	Capacity (t)
		h1	h3	h3+h13	h4	h2	(t) c=600 mm
Simplex	mm	2.085	1.565	1.650	2.085	/	1.2
Duplex	mm	2.005	2.815	2.900	3.400	/	1.2
	mm	2.355	3.515	3.600	4.100	/	1.0
	mm	1.960	4.115	4.200	4.795	1.410	0.75
	mm	2.110	4.565	4.650	5.245	1.560	0.60

* option

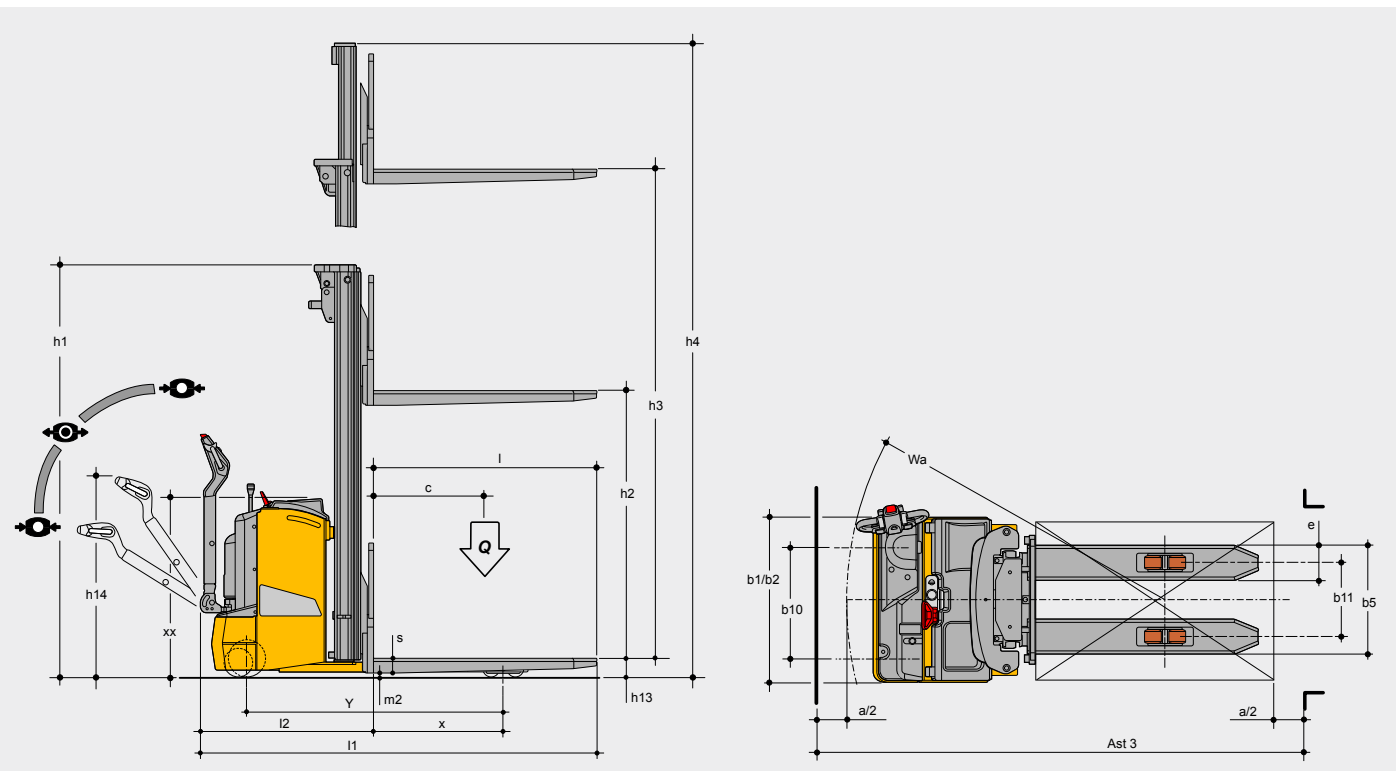



The configuration with four fixed points of support offers the maximum lateral stability granting the best safety and comfort levels during stacking and picking operations. The lifting / lowering by hydraulic lever or by mini-joystick on tiller arm, option, ensuring a precise and sensible load lifting and a proportional lowering, allows the operator to handle the load without taking the hands off the tiller arm. Exact and sensitive lifting of the load thanks to the hydraulic motor equipped with a flow regulation system reducing the noise level. The lifting and lowering speed has been improved allowing faster operations.

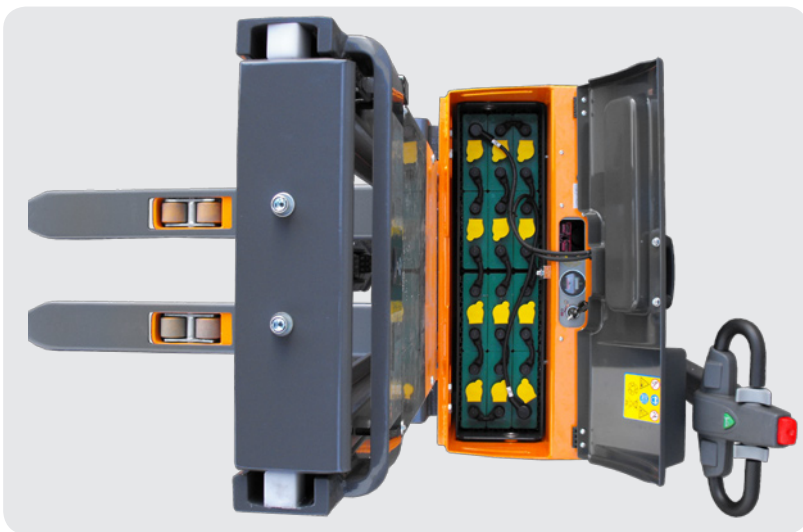

The battery compartment is easily accessed by simply lifting the hinged lid, thus facilitating daily and periodical battery checks and recharging. Focus ac is equipped with traction batteries up to 375 Ah. The wo-wa built-in charger (option) provides easy and reliable charging at any plug socket.



OMG S.r.l.

Legal Seat:

Corso Buenos Aires,18 - 20124 Milano

Seat:

Via dell'Artigianato, 12 - 46023 Gonzaga (MN) Italy Tel. +39 0376 526011 Fax +39 0376 588008

www.omgindustry.com - info@omgindustry.com

