

G series / INTELLIGENT
ENVIRONMENT-FRIENDLY



1.5-2 t

G Series 3-wheel Electric Counterbalance Forklift Truck



- > Newly designed wide-view mast with special chains enlarges operator's view effectively.
- > Three speed mode, high performance
- > Finger switch as option, more speedy operation
- > Side battery as option, easy replacement
- > Automatic deceleration on curved road, more intelligent and safe.
- > Larger battery capacity for longer single shift time
- > Imported drive and lift component for higher efficient.

HELI
LIFTING THE FUTURE

25 YEARS

TOP1 FORKLIFT MANUFACTURER AND SALER
IN CHINA FOR CONSECUTIVE 25 YEARS



G 1.5-2t G series 3-wheel Electric Counterbalance Forklift Truck



Manufacturer's Data and Design Characteristics

character		HELI					
1.01	manufacturer						
1.02	Model	CPD15SQ-GB	CPD16SQ-GB	CPD18SQ-GB	CPD18SQ-GD	CPD20SQ-GD	
1.03	Load Capacity	Q(t)	1500	1600	1750	1750	2000
1.04	Load Distance	L2(mm)	365	365	365	365	365
1.05	Wheelbase	L1(mm)	1292	1400	1400	1508	1508
size							
2.01	Mast/fork carriage tilt forw./back.	deg.	5/7	5/7	5/7	5/7	5/7
2.02	Overhead load guard (cab) height	H4(mm)	2040	2040	2040	2040	2040
2.03	Length to fork face	L'(mm)	1831	1955	1955	2063	2068
2.04	Overall Width	W2 (mm)	1060	1060	1120	1120	1120
2.05	Ground Clearance,at mast,Loaded	H5(mm)	90	90	90	90	90
2.06	Ground Clearance,at centre of wheelbase,Loaded	H6(mm)	100	100	100	100	100
2.07	Turning Radius	Wb(mm)	1477	1585	1585	1693	1703
performance							
3.01	Travel speed,with/without load	km/h	16/16	16/16	16/16	16/16	16/16
3.02	lifting speed,with/without load	m/s	0.38/0.6	0.46/0.6	0.43/0.6	0.43/0.6	0.4/0.6
3.03	Gradient performance with/without load	%	20/33	20/33	20/33	20/33	20/33
Weight							
4.01	Service weight	kg	3000	3200	3300	3350	3450
Tyre							
5.01	Tyre Type		SE	SE	SE	SE	SE
5.02	Tyre,size,front		18x7/8	18x7/8	200/50-10	200/50-10	200/50-10
5.03	Tyre,size,rear		15x4.5x8	15x4.5x8	140/55-9	140/55-9	140/55-9
Battery							
6.01	Battery voltage/rated capacity(5h)	V/Ah	440	625	625	750	750

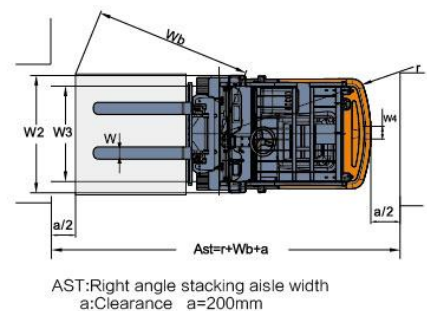
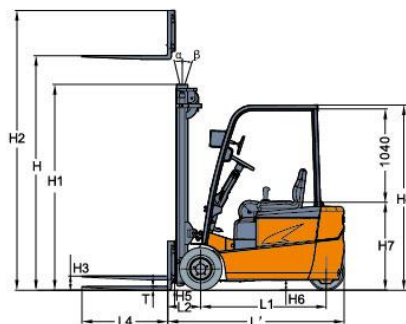
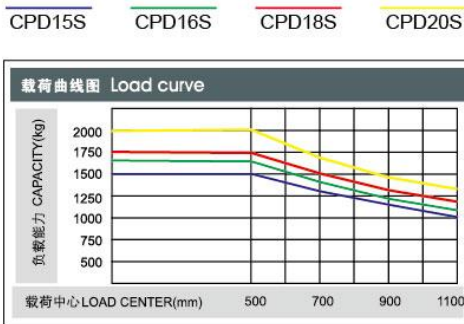

ANHUI HELI CO., LTD.

ADD: NO.668 Fangxing Street,Economical Development Zone,Hefei,P.R.China
 TEL : (86 551)63639068,63639258,63639358,63662105
 FAX : (86 551)63639966
 WEBSITE : <http://www.helichina.net>
 Email : heli@helichina.net

AUTHORIZED DEALER

* Details of specifications and equipment are based on information available at time of printing and may change without notice.